

Translation



Operating Instructions RaptorX-SL-Series

SL1200-S15 / S20 ▪ SL2200-S15 / S20 ▪ SL3200-S15 / S20

<https://www.cnc-step.de/en>



Status: 29.11.2017



RaptorX-SL-Series



Short description

The machine includes the complete mechanics for three-dimensional movement. The application range of the RaptorX- SL CNC milling machine is extremely wide due to the adjustable work surface height (variable bridge clearance: 150mm, 300mm or 400mm) plus the travel range of the Z axis of 300mm (at no extra cost). This operating description will show you how to install, operate and service a CNC- portal system.

Contents

1 GENERAL	7
1.1 Information about this Manual.....	7
1.2 Explanation of Symbols	7
SAFETY INSTRUCTIONS.....	7
1.3 Limitation of Liability.....	9
1.4 Copyright Protection.....	9
2 SAFETY	10
2.1 Appropriate Use	10
2.2 Basic Dangers.....	11
2.2.1 Danger in Electrical Systems	12
2.2.2 Danger of Mechanical Parts.....	13
2.2.3 Danger due to High or Low Temperatures	16
2.2.4 Danger of Fire	17
2.2.5 Danger of Radiation.....	18
2.2.6 Danger from Chemical Compounds	19
2.2.7 General Dangers in the Workplace	20
2.3 Responsibility of the Operator	20
2.4 Staff Requirements.....	22
2.4.1 Qualifications	22
2.4.2 Training.....	23
2.5 Personal Protection Equipment	24
2.6 Safety Systems	25
2.6.1 Description of the Installed Safety Devices.....	26
2.6.2 Safety Devices to be fitted by the Operator	29
2.7 Securing against Accidental Starting	30
2.8 Behaviour in case of Fire or Accident	31
MEASURES IN CASE OF ACCIDENT	31
OR FIRE.....	31
2.9 Environmental Protection	32
2.10 Labels and Signs.....	32

2.10.1	Advisory Signs.....	33
2.10.2	Prohibitory Signs	33
2.10.3	Warning Signs.....	35
2.10.4	Fire Protection Signs.....	36
2.10.5	Rescue Signs	37
3	TECHNICAL SPECIFICATIONS.....	38
3.1	General Specifications.....	38
3.2	Power Supply	40
3.3	Power Usage.....	40
3.4	Operating Requirements	41
3.5	Lubricants	41
3.6	Emissions.....	42
3.7	Name Plate	42
4	ASSEMBLY AND COMMISSIONING	43
4.1	Overview	43
4.2	Short Description.....	44
4.3	Description of Sub-Assemblies	46
4.3.1	Y-Axis with Slide	46
4.3.2	Z-Axis with Slide.....	47
4.3.3	X-Axis with Slide	48
4.3.4	Operating Software	48
4.3.5	Controller	49
4.3.6	Accessory Holder.....	50
4.4	User Controls	50
4.5	Connections.....	51
4.6	Working and Danger Areas	52
5	TRANSPORTATION, PACKAGING AND STORAGE	53
5.1	Safety Instructions for Transportation	53
	OFF BALANCE CENTRE OF GRAVITY	53
	FALLING HAZARD BY LOAD OFF BALANCE OR CENTRE OF GRAVITY	53
5.2	Transport Inspection.....	54
5.3	Packaging	54

CAUTION!	55
ENVIRONMENTAL DAMAGE CAUSED BY INAPPROPRIATE DISPOSAL!	55
5.4 Icons on the Packaging	55
5.5 Transportation	56
5.6 Storage	57
6 INSTALLATION AND COMMISSIONING	58
6.1 Safety Information for Installation and Commissioning	58
6.2 Preparation	60
6.2.1 Placing Machine.....	60
6.2.2 Adjusting Table Top	62
6.3 Installation	63
6.3.1 Connecting the Computer	63
6.3.2 Connecting the Stepper Motors	64
6.3.3 Installing Accessories	65
6.4 Connecting to Power Supply	66
6.5 Commissioning	67
7 OPERATION	68
7.1 Safety Instruction for Operation	68
7.2 Important Steps before Operation	68
7.3 Switching-On Procedure	69
7.4 Important Steps during Operation	69
7.4.1 Clamping of Work Pieces or Materials.....	69
7.4.2 Operating of the Machine	70
7.4.3 Tool Changes	75
7.5 Switching-Off Machine	77
7.6 Important Steps after Operation	77
7.7 Emergency Stop	78
8 MAINTENANCE	79
8.1 Safety during Maintenance	79
8.2 Spare Parts	80
8.3 Maintenance Schedule	82
8.4 Maintenance Procedures	83

8.4.1	Cleaning Machine	83
8.4.2	Protection Cover Inspection or Replacement	83
8.4.3	Machine Lubrication	86
8.5	Steps to be taken after Maintenance Procedure	92
9	TROUBLE SHOOTING	93
9.1	Safety during Trouble Shooting	93
9.2	Table of Faults	95
9.3	Fault Repair	96
9.3.1	Releasing the Emergency Stop Switch	96
9.3.2	Changing the Electrical Fuse	97
9.4	Start-up after Fault Repair	98
10	DISASSEMBLING AND DISPOSAL	99
10.1	Safety during Disassembling and Disposal	99
10.2	Disassembling	99
10.3	Waste Disposal	100
	CAUTION!	100
	ENVIRONMENTAL DAMAGE CAUSED BY INCORRECT DISPOSAL!	100
11	APPENDIX	101
11.1	Accessories	101
12	CUSTOMER SERVICE	102



1 General

1.1 Information about this Manual

This manual enables you to safely and efficiently handle this machine.

The guide is part of the machine and has to be kept close to the machine accessible to the staff at any time. Before starting any work the operator needs to have read and understood this manual. Basic condition for a safe operation of the machine is the compliance with all safety rules and instructions given in this manual.

In addition, the local accident prevention regulations and general safety rules must be applied during the operation of the machine.

Illustrations or graphical representations in this manual serve the fundamental understanding and may differ from the actual construction of the machine.

In addition to these instructions, the instructions in the annexure of the assembled components, apply accordingly.

1.2 Explanation of Symbols

Safety instructions

Safety instructions in this guide are marked by symbols. The safety instructions are initiated by key words, which show the degree of the danger.

Safety precautions have to be observed strictly and cautious action has to be taken in order to avoid any accidents as well as damages to persons or property/objects.



DANGER!

Indicates an imminently dangerous situation which may cause serious injury or death if ignored.



WARNING!

Indicates a potentially dangerous situation which could lead to serious injury or death if ignored.



CAUTION!

Indicates a potentially dangerous situation which could lead to minor or mild injury or damage to property if ignored



ATTENTION!

The symbols or a combination of symbols highlight potential dangers that can result in injury to persons or damage to property if ignored.

Important safety symbols

To draw attention to special dangers the following symbols are used in the safety instructions:



DANGER!

A combination of this symbol and warning indicate danger of potential electrocution which could result in personal injury or death if ignored



Tips and Recommendations





NOTE! - highlights useful tips and recommendations as well as information for an efficient and trouble-free operation.

Other symbols and icons

The below mentioned symbols are used to indicate further information relating to the correct use of the machine:

Symbol	Description
	Step by step instructions
	Results by specific actions

	Reference to appendix or other parts of the manual
	List without a specific order

1.3 Limitation of Liability

All information and instructions in this manual have been made under consideration of the applicable standards and regulations, the state of technology as well as our long-standing knowledge and experience.

The manufacturer assumes no liability for damages due to:

- Failure to comply with the instructions in this manual
- Non-specified use
- Operations by un-qualified staff
- Unauthorized alterations or modifications
- Technical changes
- Use of unauthorized spare parts

For special designs, additional ordering options or due to some late technical modifications, the actual delivery may not necessarily correspond to the presented explanations and descriptions.

General terms and conditions as well as the delivery terms of the manufacturer as agreed on the delivery contract and all legal provisions valid at the time of the contract fulfilment, will apply. We reserve the right to implement technical changes and amendments to the manual and machines as part of the improvement program of the performance and further development of the platforms.

1.4 Copyright Protection

This manual is copyrighted and designed exclusively for internal purposes.

Release of the manual to third parties, reproductions of any type or form, extracts or parts thereof and communication of the contents are not permitted without the written permission of the manufacturer except for internal purposes.

Any breach of this obligation shall result in liability for damages. The right to any further claims remains reserved.



2 Safety

This section provides an overview of all important safety aspects for optimal protection of the staff as well as a safe and trouble-free operation.

Failure to follow the operating procedures and safety instructions listed in this manual may lead to significant dangers.

2.1 Appropriate Use

The machine is designed and constructed to be used only in accordance with its intended purpose as described in this manual.

The CNC milling machine/ milling machine is exclusively designed, constructed and to be used for engraving, drilling, milling, cutting, lasing, dispensing / mixing, measuring and plasma cutting. Only water soluble lubricants may be used.

The machine is intended for implementation in a plant and does not have a separate control. There is no operating staff necessary during operation.

Appropriate use also includes the adherence to all information in this manual as well as the instructions pertaining to the components.

Any use exceeding or differing from the appropriate use is considered misuse and can lead to dangerous situations.



WARNING!

Danger resulting from misuse!

Misuse of the machine can lead to dangerous situations!

- Use of the machine outside of the given specifications
- Disabling or removal of any safety switches
- Modification or changing of the machine resulting in changes to the working area or operational parameters.
- Operation of the machine with flammable coolants.

- Machining of metals like Magnesium, Aluminium and Titanium without extraction or correct procedures
- Operation of the machine with a technical fault.
- Operating the machine in an explosive environment.

Any claims resulting from misuse or incorrect handling of the machine will not be entertained.

2.2 Basic Dangers

In the following section remaining risks are listed which have been identified on the basis of a risk assessment.

The safety instructions and warnings given in the other chapters of this manual have to be observed to reduce health risks and to avoid dangerous situations.

2.2.1 Danger in Electrical Systems

Electricity



DANGER!

Risk of death by electrocution!

Contact with live electrical parts present an imminent danger to a person's health. Damaged insulation or components can cause fatal electrocution if touched by a person.

- Only qualified electricians are allowed to work on the electrical systems.
- In case of damage to the insulation, disconnect the power supply immediately and arrange for repairs.
- During all work on the electrical systems, disconnect from the mains and verify that the disconnected parts are free of voltage. These five rules apply:
 - Disconnect from main supply
 - Secure against accidental reactivating.
 - Check for current.
 - Check earthing and short circuit.
 - Shield or disconnect any neighbouring machines.
- Do not bridge or disable fuses. When changing fuses observe correct amperage
- Protect live parts from moisture. Moisture can lead to short circuiting.



Stored electrical charge



DANGER!

Risk of death by electrocution from stored energy!

Electrical charge may be stored in electrical components which could result in electrocution causing injury or death.

- Before commencing work, turn off the power and wait for 10 min before continuing, to allow condensers time to discharge the stored current.

2.2.2 Danger of Mechanical Parts

Rotating tools



WARNING!

Risk of injury by rotating parts!

The milling tools clamped in the spindle motor can cause serious injury to persons or damage to property

- Before start of work verify that the safety devices are functional and installed properly and that the required covers are closed.
- During operation do not touch the rotating tools
- Before changing tools always secure machine against an accidental restart or uncontrolled movements.



Moving Axis



WARNING!

Risk of injury by moving axis!

Collisions between persons and machine (Y-Axis, Moving parts, Rotational axis, Tools) may lead to serious injuries.

- Keep clear of moving parts and their end-stops
- Never reach between the machine and rails
- Only perform maintenance on linear guides when machine is switched off
- Always wear protective clothing in the work area.

Rack and Pinion



WARNING!

Risk of injury by moving rack and pinion gear

While operating clothing, hair or body parts could get caught in the rack and pinion leading to serious injury.

- Never reach over rack and pinion when machine is switched on.
- Maintenance may only be performed while the machine is turned off.
- Always wear protective clothing in the working area.



Falling materials



WARNING!

Risk of injury by falling materials!

While operating off cut debris, materials or tools may be ejected from the work area causing serious injury to face or eyes

- Always wear face and eye protection, gloves and safety shoes
- In the event of an injury, contact the medical personnel

Uncontrolled restart



WARNING!

Uncontrolled restart can cause serious personal injury or death!

The machine could move unexpectedly or change direction unexpectedly resulting in injury

- Keep body parts away from the machine working area
- Secure work area against accidental access.

Tools



CAUTION!

Risk of injury by incorrect handling of tools
The incorrect handling of tools may result in injuries.

- Handle tools carefully and correctly.
- When transporting tools be aware of the weight of the equipment.
- Wear proactive gloves and safety shoes.



Sharp edges and corners



CAUTION!

Danger of injury from edges and corners!

Sharp edges and corners can cause skin-abrasions and cuts.

- be cautious when working near sharp edges or corners
- If necessary wear protective gloves.

2.2.3 Danger due to High or Low Temperatures

Hot Surfaces



CAUTION!

Danger of injury from hot surfaces!

Tools, work-pieces and chippings may heat up to high temperatures. Contact with these surfaces could result in severe burns to the skin

- When operating the tools or work-pieces always wear heat resistant clothing and gloves.
- Before starting work ensure that all surfaces have reached ambient room temperature.



2.2.4 Danger of Fire

Highly flammable materials



WARNING!

Danger of fire through flammable materials!

Organic dust from wood or coal and inorganic dust from Magnesium, Aluminium, Zink or Titanium may start combusting which may result in serious injury or death

- Do not smoke near the working or danger area and avoid open flames or other potential fire risks.
- Always have a fire extinguisher near the machine.
- When working with Magnesium, Aluminium, Zink or Titanium an extraction system is required and caution must be observed.
- In case of fire, stop working and evacuate the area. Activate the fire alarm.



2.2.5 Danger of Radiation

Magnetic field radiation



DANGER!

Danger from magnetic field radiation!

Magnetic fields pose a danger to persons and property

- Persons with Pace-Maker may should not work on or approach the machine. The Pace-Maker may be affected.
- Persons with metal implants should not work on or approach the machine. The implants may heat up or be pulled towards the machine.
- Do not wear any jewellery like rings, necklaces, watches etc. when operating the machine.
- Do not place any electronic equipment near the magnetic fields as these may be damaged
- Do not place any data storage devices or credit cards, etc. near the magnetic fields as these may be wiped out.

2.2.6 Danger from Chemical Compounds

Cooling fluids



WARNING!

Danger from exposure to toxic cooling fluids!

Exposure of the skin to toxic cooling fluids or emulsions

can result in irritation or chemical burning.

- Inspect the cooling fluids at regular intervals.
- When working with coolants wear correct protective clothing and chemical resistant gloves.
- Avoid direct contact between chemicals and unprotected skin.
- Do not consume or store food or drinks in the work area



CAUTION!

Health risk from exposure to toxic cooling fluids!

Contact with Toxic coolants can result in illness

- Avoid direct skin contact.
- Wash skin immediately after contact with coolants.
- Avoid breathing fumes or gases from the coolants.

Oil and Grease



Caution!

Health risk from exposure to oils and grease!

Contact with Toxic coolants can result in illness.

- Avoid direct skin contact.
- Remove oil or grease from skin immediately
- Avoid breathing fumes or gasses from oils or grease.

2.2.7 General Dangers in the Workplace

Notice



WARNING!

Danger of damage to hearing from loud noise.

The noise levels in the work area can cause serious damage to hearing.

- Always wear ear protection.
- Avoid exposure to noise where possible.

Dirt and Debris in the Workplace



CAUTION!

Risk of stumbling and resulting injury through dirt and debris lying around!

Dirt and debris lying around are a source for slipping and stumbling and can result in serious injuries.

- Always keep work area clean
- Remove items no longer needed.
- Mark potential stumbling spots with yellow-black marker tape

2.3 Responsibility of the Operator

Operator

The Operator is the person using the machine for business or commercial purposes directly or through a 3rd party, who will carry the legal responsibility for the use of the machine.



Responsibility of the Operator

The machine is used in the commercial sector. Therefore the operator of the machine is subject to the statutory requirements for operational safety.

In addition to the safety instructions mentioned in this manual the valid safety regulations and rules for accident prevention as well as the environmental protection law have to be observed.

In particular the following must be adhered to:

- The operator has to be informed about the valid industrial safety regulations and an evaluation of possible additional dangers may need to be done to determine any further potential hazards in order to enhance the safety of working conditions at place of operation.
- During the entire operating time of the machine the operator has to verify that the Standard operating procedures (SOP) prepared by him or his company are in accordance with the current regulations and adjust them if necessary.
- The operator has to clearly define and regulate the responsibilities for installation, operation, maintenance and cleaning.
- The operator has to ensure that all staff who deals with the machine have read and understood the instruction manual. In addition, the staff must be regularly trained and informed about the dangers.
- The operator has to provide the necessary protective equipment for the staff.
- The operator is responsible for installing circuit breakers on doors or any other movable devices. Limit switches have to be installed on any movable safety devices as well as on any doors and they must be integrated into the control system. Only after this has been completed can we supply a CE Declaration instead of the manufacturer's declaration.



If a security fence or protection has been installed as per the instruction manual, a CE certificate may be supplied with the machine in place of a manufacturer's declaration.



The operator is responsible for ensuring that the machine is always in perfect technical condition, therefore the following applies:

- The operator has to ensure that the maintenance intervals are kept as described in this manual.
- The operator has to check and test all safety equipment regularly for functionality and completeness.

2.4 Staff Requirements

2.4.1 Qualifications

This section describes the various actions and qualifications required by the operator designated to operating the machine.



WARNING!

Risk of injury in case of insufficient user training!

Improper use or handling can result in significant injury or damage to persons and property.

Therefore:

- Operations to be carried out by qualified staff.
- Unqualified personnel are to remain clear of the working area.

Only persons whose work performance is reliable may be considered as staff. Persons whose ability to perform is influenced or impaired by drugs, alcohol or pharmaceuticals, are not to be considered.

The manual requires the following staff qualifications for different areas of operation.

User

Staff that has been trained by the operator about the operations assigned to them and about the potential danger in case of improper or incorrect usage.

Electrician

Qualified Tradesmen (Electrician) that due to their professional training, knowledge and experience as well as their knowledge of the relevant standards and regulations and are in a position to work on electrical equipment and are able to detect and avoid potential danger independently.

The electrician is trained for his specific area of operation and knows the relevant standards and regulations.

Qualified Staff

Qualified Staff with professional training, knowledge and experience as well as knowledge of the relevant regulations that are in a position to carry out operations or tasks assigned to them and are able to detect and avoid potential dangers independently

Manufacturer

Certain functions may only be carried out by qualified persons from the Manufacturer. For information regarding the functions described please contact the Service centre.

2.4.2 Training

The staff has to be trained regularly by the operator. For better traceability the implementation of the training has to be recorded in writing.

- Date of training
- Name of person trained
- Type of training given
- Name of the instructor
- Signature of trainer and trainee



2.5 Personal Protection Equipment

While working the wearing of personal protection equipment is needed to minimize health hazards and risks of injury. The personnel must wear the correct protective clothing and related equipment described here, at all times.

Description of protective clothing and equipment

Below is a list describing the required protective clothes and equipment:



Protective Work Clothing

Must be tight-fitting work clothing with a low tensile strength, narrow or tight sleeves and no protruding parts.



Chemical resistant gloves

As protection for the hands against chemical irritants.



Ear protection

As a protection against hearing damage due to noise



Safety helmet

Industrial safety helmet to prevent possible head injuries from falling items or other risks.



Protective Goggles

To protect the eyes from flying debris and liquid splashes.



Protective Gloves

As protection for the hands against friction, abrasion, grazing or cuts as well as possible contact with hot surfaces.



Hair Net

To protect the hair from being caught in machinery or rotation tools.



Safety Shoes

As a protection against heavy falling objects and to provide traction on slippery surfaces

2.6 Safety Systems



WARNING!

Danger of injury or death by non-functioning safety systems!

Safety is only ensured with fully functioning safety devices.

- Before start of work verify that the safety devices are functional and installed properly.
- Never disable safety devices
- Ensure that safety devices such as emergency stop buttons, interrupt switches or emergency trip switches are accessible

2.6.1 Description of the Installed Safety Devices

Emergency Stop Switch

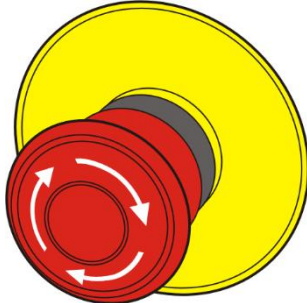

Fig. 1: Emergency Stop Switch

By pressing the emergency stop button an emergency stop is triggered and the drive motors are physically disconnected preventing any movement.

After the emergency stop button has been pressed it must be unlocked by twisting so that restarting is possible.



WARNING!

Danger to life through uncontrolled restart!

Uncontrolled restart can cause serious personal injury or death.

- Before restart ensure that the cause for the emergency stop has been eliminated, that all safety devices have been reassembled and are functional.
- Only unlock the emergency stop button if there is no further danger

Location of the Emergency Switches

Fig 2 Shows the location of the Emergency Stop Switches



This symbol indicates an Emergency Stop Switch

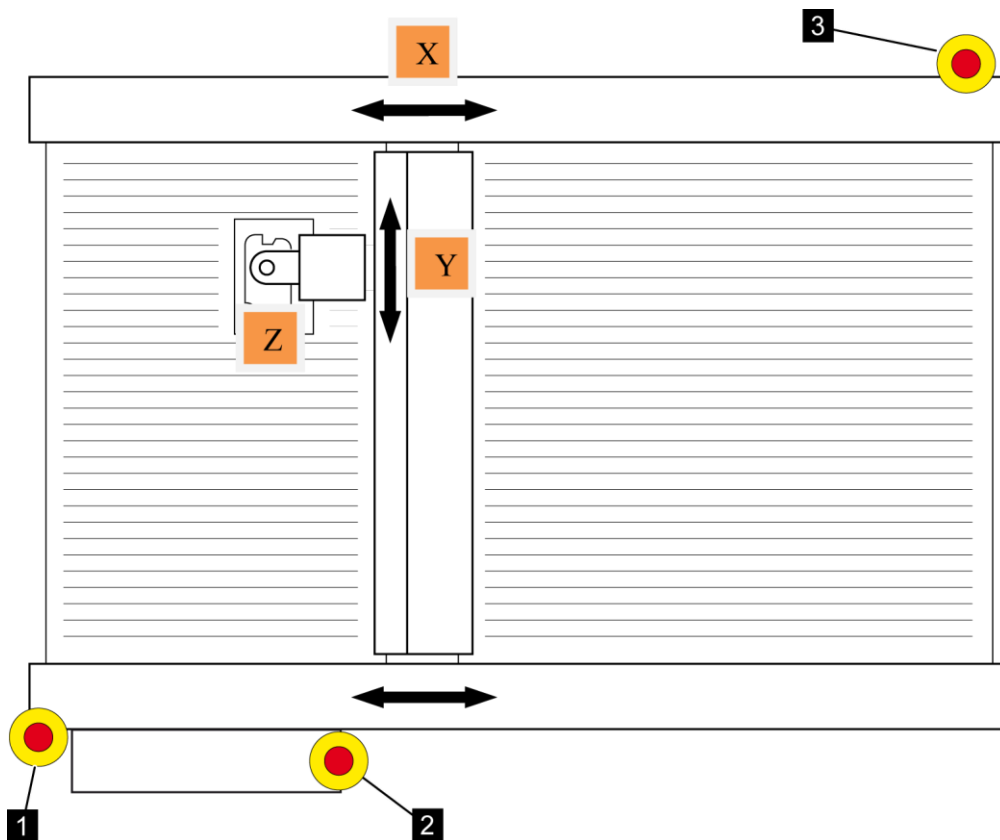

Fig. 2: Position of the Emergency stop switches (Top view)

- | | |
|--|---|
| <p>1 Emergency stop switch on left front of machine</p> <p>2 Emergency stop switch on Controller box</p> | <p>3 Emergency stop switch on right back of machine</p> |
|--|---|

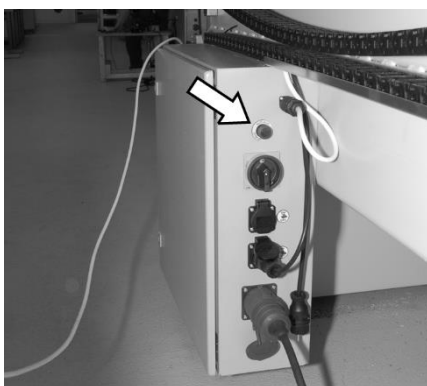

Fig. 3: Emergency stop switch on controller box

The emergency stop button on the controller housing (Fig. 2/2 und Fig. 3/Arrow) has to be unlocked twice.

Main Switch with Emergency Function



Abb. 4: Main switch

The main switch is also an emergency stop button. By turning the main switch to the "0" position the power supply is immediately disconnected and an emergency stop is triggered.

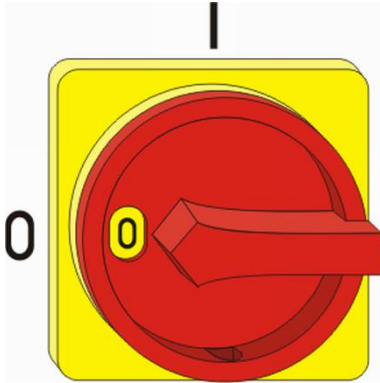

WARNING!

Danger to life through uncontrolled restart!

Uncontrolled restart can cause serious personal injury or death!

- Before restarting ensure that the cause for the emergency stop has been eliminated, that all safety devices have been reassembled and are functional.
- Only turn the main switch to the "I" position when it is safe to do so.

Location of the Main Switch

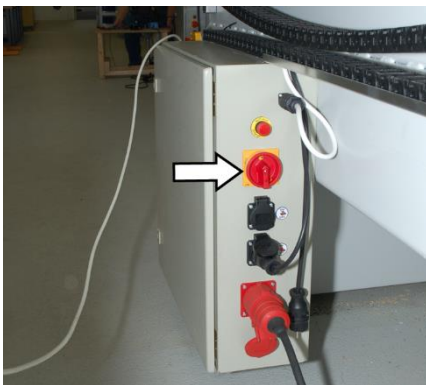

Fig. 5: Controller box

The Main switch is located on the controller box (Fig. 5/Arrow).

2.6.2 Safety Devices to be fitted by the Operator



The operator must install the following safety devices, which are available as optional accessories:

Safety Fences and Covers

The Machine is to be installed as part of a system. Before using the machine, ensure that all safety fences or covers are installed and connected to the main controller on the safety circuit.

Covers serve to protect against debris, dust or parts that may eject from the working area

Fences serve to protect the working area from intrusion while machine is running.

Use the correct entrance to access the machine and never turn on power while persons are in the working area.

Limit switches as access control

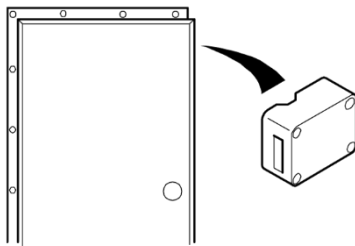

Fig. 6: Limit Switch

Limit switches are installed as accident prevention devices on doors and maintenance accesses. They prevent starting when open or turn off the machine if opened while running the machine.

Extraction

Machining of metals like Magnesium, Aluminium and Titanium requires an extraction system.

□ *Chapter Fehler! Verweisquelle konnte nicht gefunden werden. "Fehler! Verweisquelle konnte nicht gefunden werden.", page Fehler! Textmarke nicht definiert.*

2.7 Securing against Accidental Starting



WARNING!

Danger to life through uncontrolled restart!

Uncontrolled or un-authorized restart can cause serious personal injury or death!

- Before restarting ensure that the cause for the emergency stop has been eliminated, that all safety devices have been reassembled and are functional.
- Observe the following instructions to prevent un-authorized starts.

Securing Main Switch

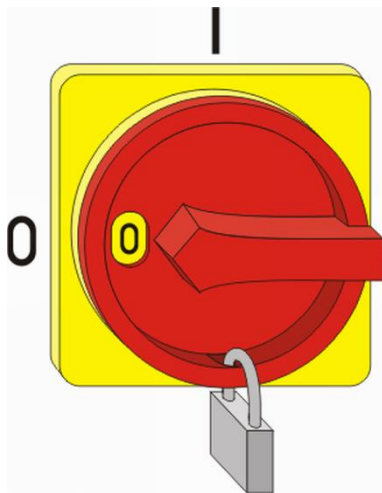

1. To turn off the power supply move the switch to the "0" position.
2. Lock the switch with a Pad-Lock (Fig. 7).
3. Keep the pad-lock key in a secure area to prevent un-authorized access.

Fig. 7: Securing main switch

2.8 Behaviour in case of Fire or Accident

Preventative measures

- Always be prepared for accidents or fire!
- Keep first-aid equipment (first-aid kit, blankets etc) and fire extinguisher within reach.
- Familiarize staff with accident reporting and first-aid equipment as well as rescue facilities
- Keep access roads clear for emergency vehicles

Measures in case of accident or fire

- Trigger Emergency-Stop immediately.
- Rescue persons from the danger area when it is safe to do so.
- Start first-aid measures if necessary.
- Alert rescue services
- In case of fire, if there is no immediate danger to life, use fire extinguishers to control the fire until fire services arrive.
- Inform the responsible persons immediately.
- Keep access roads clear for emergency vehicles.
- Direct rescue services onto the premises.

2.9 Environmental Protection



NOTE!

Danger to the environment from incorrect handling!

Incorrect handling of environmentally hazardous substances, particularly incorrect disposal, can cause significant damage to the environment.

- Observe instructions below.
- Take appropriate action immediately if environmentally hazardous substances enter the environment accidentally. When in doubt, inform the competent local authority about the damage.

The following environmentally hazardous substances are used:

Lubricants

Lubricants such as greases and oils contain toxic substances. These must not enter the environment. The waste disposal has to be done by a specialized waste company

Gearbox Oils

Gearbox oils contain toxic substances. These must not enter the environment. The waste disposal has to be done by a specialized waste company

Coolants

Coolants may contain toxic substances such as Glycol. These must not enter the environment. The waste disposal has to be done by a specialized waste company

2.10 Labels and Signs

The following symbols and signs will be visible in the work space. These will be relevant to the area where the symbol or sign is displayed.



WARNING!

Risk due to illegible signs or symbols!

Over time labels, signs and symbols might become un-readable or obscured resulting in risk of injury due to hazards not recognized in the absence of a legible warning sign.

- Regularly maintain all labels, signs and symbols so they are clearly visible and legible.
- Replace any damaged or illegible labels or signs.

2.10.1 Advisory Signs

Refer to User Manual



Use the machine only once the described signs and symbols have been understood by referring to the user manual.

2.10.2 Prohibitory Signs

Persons with Pace-Makers prohibited



No persons with a Pace-Maker are allowed to approach the area where this sign is displayed. There is a danger of electromagnetic radiation which may disrupt the function of a Pace-Maker resulting in death.

Persons with metal implants prohibited



Persons with metallic implants should avoid the area where this sign is displayed. Radiation may cause implants to heat up causing bodily harm.



**Operating while wearing
jewellery prohibited**



Wearing jewellery which may get caught in the workings of the machine, possibly causing injury or death is prohibited in the areas displaying this sign.

**Operating while wearing
neckties prohibited**



Persons wearing a neck tie are prohibited from entering the area displaying this sign. The neck tie may get caught in the workings of the machine causing injury or death.

**Operating with long hair is
prohibited**



Persons with long hair are prohibited from operating the machine unless they are wearing a hair net or hair protection. The hair may be caught in the working parts causing injury or death.



2.10.3 Warning Signs

Electrical Current



Only qualified electricians are allowed to work on the electrical systems displaying this sign.

No un-authorized persons are allowed to open doors with this sign and should keep clear of the area.

Automatic Start



The signals, a flashing light or acoustic siren denote the automatic starting of production line machines. At this point all work in the area must be complete. After the signal, clear the area immediately.

Avoid any moving parts that may cause injury.

Hott Surfaces



Hot surfaces, tools, liquids and other potential hazards may not be recognizable. Where this sign is displayed be sure to wear protective gloves before handling any items.

2.10.4 Fire Protection Signs

Emergency Phone



This phone may only be used in an emergency.

Before commencing fire fighting activities, use the phone to alert the emergency services.

A conventional telephone may be used in an emergency to contact emergency services and alert responsible persons.

The following information will be required:

- Who is calling?
- Nature of the emergency?
- How many persons affected/injured?
- Where did the incident take place?
- Respond to any questions asked!

Fire Extinguisher



Guideline for using fire extinguisher.

Before activating the fire extinguisher ensure that all persons are clear of the area and warn persons before commencing with extinguisher.

Only use fire extinguisher on fire.

2.10.5 Rescue Signs

First Aid



This sign indicates a first aid kit placement.

If this sign is accompanied by any other signs i.e. Medic, this will indicate that a medic is on duty.

In an emergency use the contents of the kit to provide first aid to patients.

If any items are used in the first aid kit, this must be noted and replacements provided.

Emergency Exit



In case of emergency use this exit to leave the area.

Emergency Phone



This phone may only be used in an emergency.

Use the phone to alert the emergency services.

The following information will be required:

- Who is calling?
- Nature of the emergency?
- How many persons affected/injured?
- Where did the incident take place?
- Respond to any questions asked!

Escape Route



In an emergency use the escape route to leave the area. The escape routes must always be kept clear and free.

3 Technical Specifications

3.1 General Specifications

Machine General

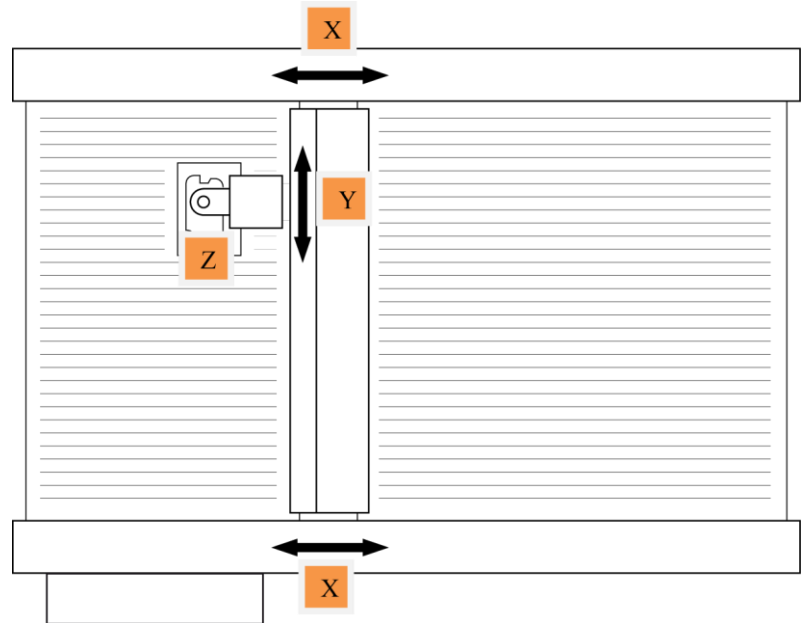

Fig. 8: Machine (Top View)

Description	RaptorX-SL S-1200		RaptorX-SL S-2200		RaptorX-SL S-3200	
	S15	S20	S15	S20	S15	S20
Length (X)	1500 mm	1500 mm	2500 mm	2500 mm	3500 mm	3500 mm
Width (Y)	2220 mm	2720 mm	2220 mm	2720 mm	2220 mm	2720 mm
Height (Z)	1700 mm	1700 mm	1700 mm	1700 mm	1700 mm	1700 mm
Weight without work table	ca. 780 kg	ca. 820 kg	ca. 900 kg	ca. 1040 kg	ca. 1020 kg	ca. 1160 kg
Clamping area (LxB)	1500 x 1700 mm	1500 x 2200 mm	2500 x 1700 mm	2500 x 2200 mm	3500 x 1700 mm	3500 x 2200 mm
Bridge clearance	50–400 mm (50/150/300/400 mm depending on the table top support struts) When raw material mounted on the floor up to 850mm (Caution! Limited x-axis travel) Bottom of bridge and milling spindle adaptor to table top support struts					

Cutting area

Axis	RaptorX-SL S-1200		RaptorX-SL S-2200		RaptorX-SL S-3200	
	S15	S20	S15	S20	S15	S20
X-axis	1200 mm	1200 mm	2200 mm	2200 mm	3200 mm	3200 mm
Y-axis	1510 mm	2010 mm	1510 mm	2010 mm	1510 mm	2010 mm
Z-axis	300 mm	300 mm	300 mm	300 mm	300 mm	300 mm

Z-axis optional 600 mm extension available.

Other Parameters

Parameter	Description
positioning speed, maximum	40.000 mm/min ¹
Working Speed (depending on form and ramp), maximum	20.000 mm/min ¹ (depending on form complexity and ramp speed)
Steps X/Y+Z	0,0213/0,0113 mm
Reverse direction correction	ca. +- 0,045 mm
Position Error	Can be calibrated
Reference/Limit switches	3x Magnetic contactless on all axis
Work Area Monitoring	Software Controlled
Linear guides X/Y/Z	HIWIN 20 mm / Pre-tensioned with 4 slides per axis
Drives X/Y/Z	Stepper Motor 9.4 Ampere / 9.3 Nm holding Torque.
Drive type X/Y/Z	Low back-lash precision planetary gears with 110 Nm output torque
Spindle Clamp	43 H7 Euro-neck or HF-Spindle adaptors
Cooling system (Optional)	Spray cooling with soluble cooling emulsions

¹ Measured in the diagonal drive X + Y (depending on contour shape)

If the speed is >7200mm/min you need the software WinPCNC USB or Profi!

3.2 Power Supply

Electrical (total)

Description	Value	Unit
Voltage	380	V
Frequency	50	z
Power consumption, maximum	8	kW

3.3 Power Usage

HF-Spindle (optional)

Description	Value	Unit
Current, maximum	16	A
Power consumption, maximum	3600	W

Relay Plug Points

Description	Value	Unit
Voltage	220	V
Max Current per Plug Point	8	A



The relay driven plug points are found on the controller box and on the Z-axis bridge

□ Chapter 4.5 “Connections”, page 51.

Drive motors X/Y/Z

Description	Value	Unit
Max current per Motor	9,5	A
Holding Torque	9,33	Nm



The rotational axis and tangential knives are available optionally.

3.4 Operating Requirements

Environment

Description	Value	Unit
Temperature range	16□30	°C
Max. Humidity	60	%

Duty Cycle

Description	Value	Unit
Max run time without stopping	100	h
Rest period required to next run	2	h

3.5 Lubricants

Lubricant	Type	Amount	Unit
Light machine grease	OKS 425 Synthetic Long life Grease	20	Gram per Ball Nut

3.6 Emissions

Description	Value	Unit
Sound emissions (without Spindle)	ca. 50	dB(A)
Sound emissions (with Spindle)	>70	dB(A)

3.7 Name Plate



Fig. 9: Name Plate

The name plate is attached to the frame of the machine next to the controller box and contains the following information:

- Manufacturer
- Type/Model
- Year of Manufacture
- Serial Number

4 Assembly and Commissioning

4.1 Overview

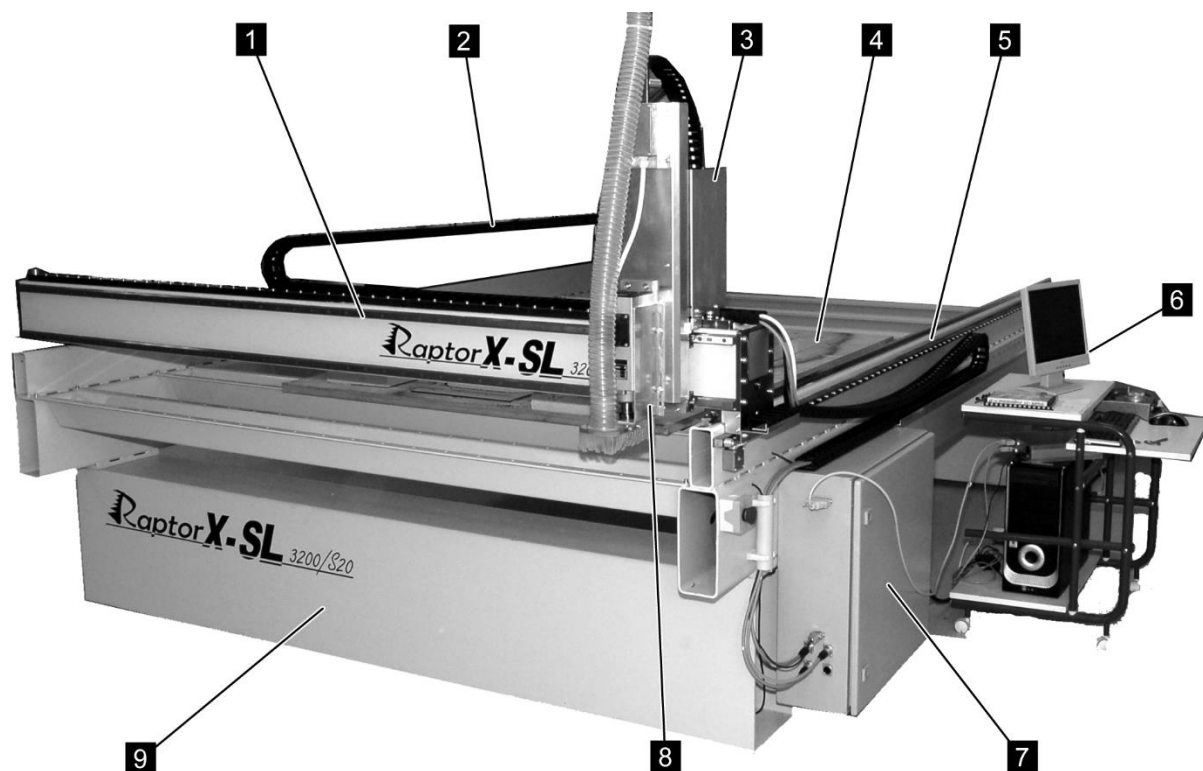

Fig. 10: Raptor overview

- | | |
|---|--|
| <p>1 Y-Axis with slide (Y-Bridge)
□ Chapter 4.3.1 "Y-Axis with Slide", page 46</p> <p>2 Cable channel</p> <p>3 Z- Axis with slide □ Chapter 4.3.2 "Z-Axis with Slide" page 47</p> <p>4 Working table</p> <p>5 X-Axis with slide □ Chapter 4.3.3 "X-Axis with Slide" page 48</p> | <p>6 Operator station with software
□ Chapter 4.3.4 "Operating Software", page 48</p> <p>7 Controller □ Chapter 4.3.5 "Controller", page 49</p> <p>8 Accessory holder on Z-Axis (Movable)
□ Chapter 4.3.6 "Accessory Holder", page 50</p> <p>9 Frame</p> |
|---|--|

4.2 Short Description

Intended use of Machine

This machine may be used for the following applications:

- 2D und 3D Milling
- 2D und 3D-Engraving
- Cutting
- Drilling
- Laser
- Water Jet
- Dispensing
- Measuring
- Welding
- Plasma cutting

Materials

The following materials may be processed:

- Plastic
- Wood
- Non-ferrous metals (Aluminium, Brass etc.)
- Glass
- Ceramic etc.
- Steel, Stainless steel etc. (Plasma burner and engraving)

Description

The machine will require some accessories which must be installed before the machine will be ready for cutting:

- Controlling software**, the machine is controlled by means of software (e.g. WinPCNC, Mach3, USB CNC) on a Window PC which connects to the machine via a RS232 serial port
- Tools**, for cutting or working the materials or work pieces
- Accessories e.g.** Tool holders, spindles, vacuum systems etc. These may be seen here *Chapter Fehler! Verweisquelle konnte nicht gefunden werden. "Fehler! Verweisquelle konnte nicht gefunden werden.", Page Fehler! Textmarke nicht definiert. .*

The work piece will be clamped onto the working table (Fig. 10/4). The milling spindle will be mounted in the tool holder (Fig. 10/8). All the movements the tool will perform are controlled via the controlling software (Fig. 10/6). Tool changes are performed manually.

The machine consists of a steel frame construction that is open to be able to mount large work pieces.

The bridge clearance is between 50-400mm from the milling spindle adaptor to the table top support struts (50/150/300/400mm, strut heights are available as accessories).

When large work pieces are mounted on the floor up to a maximum of 850mm the X-axis travel will be restricted.

Controlling software

The files that will be run on the machine will be created in a CAD or graphic design program. The drawing or text will be saved in either HPGL/dxf, AI, etc. formats. This data will be opened in the CNC-controlling software e. g. WinPCNC (optional) to be run on the machine.

All operational parameters can be set up in the software to control feed rates, cutting depths, scale etc. The motion commands are given from the software to the CNC stepper motors to perform the required movements.

The four stepper motors X-, Y-, Z- and 4th axis will receive respective commands from the software and perform the movements via the gearing.

4.3 Description of Sub-Assemblies

4.3.1 Y-Axis with Slide



1 Linear Guides

Fig. 11: Y-Slide



Fig. 12: Y-Rack

2 Rack

The two linear guides (Fig. 11/1) and the rack (Fig. 12/2) are found on the Y-bridge (Fig. 10/1) and form the Y-axis on which the milling spindle (optional) with tools are moved.

4.3.2 Z-Axis with Slide

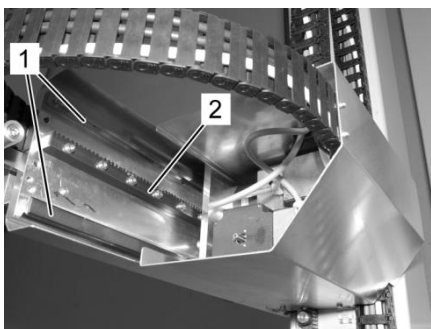

Fig. 13: Z-Slide (Top View)

1 Linear Guides

2 Rack

The two linear guides (Fig. 13/1) form the Z-Axis on which the milling spindle (optional) will be moved in the Z-direction.

4.3.3 X-Axis with Slide

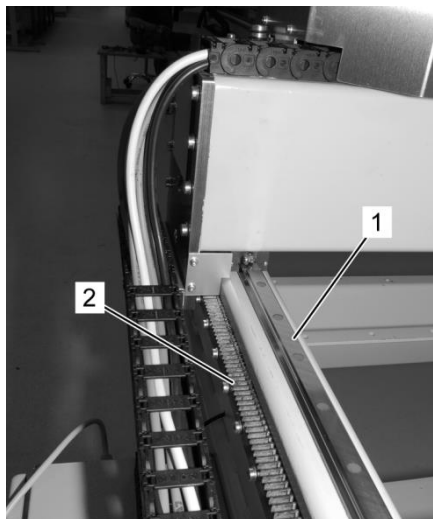

- 1 Linear Guides
- 2 Rack

The figure shows the X-linear guides (Fig. 14/1) and the X-rack (Fig. 14/2) on one side of the machine. The second X-axis with rack and guide is found on the other side of the machine. Both the X rails form the X-axis on which the Y-bridge (Fig. 10/1) is traversed.

Fig. 14: X-Slide

4.3.4 Operating Software

WinPCNC

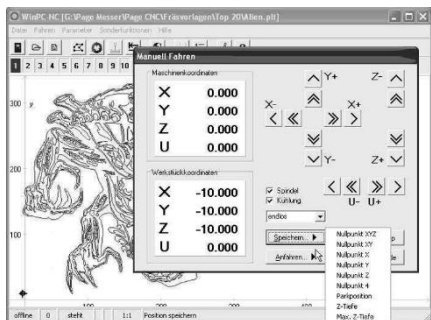

Fig. 15: Screenshot

The machine is controlled by CNC-CAM-Software.

The CAM-Software WinPCNC USB (Fig. 15) is Windows PC based software. The Profi version (optional) contains plug-ins to perform 3D-scanning.

The WinPCNC USB is supplied with the machine.



Further information is available in the software user manual supplied with the software disc.

Mach3

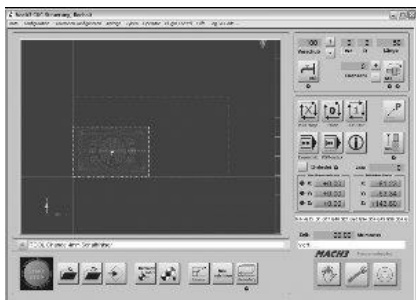

Fig. 16a: Screenshot

Mach3 (Fig. 16a) controlling software (optional) is also a Windows based CAM program. All machine settings are available for this software package.

WinPCNC USB is supplied with the machine.

4.3.5 Controller

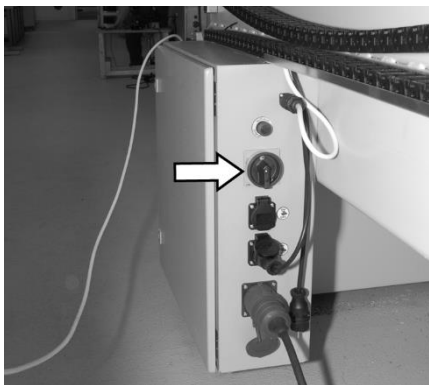

Fig. 17: Controller

The controller controls the stepper motors for each axis.

The controller (Fig. 17) is connected to the PC by a parallel port connection (RS232). It is possible to connect the PC directly to the controller via parallel port if one is using WinPCNC Economy.

WinPCNC Profi has an axis controller and will connect to the controller via serial port or USB connection.

The controller has a main switch (Fig. 17/arrow) for turning the machine on or off and the controller box may be opened with the supplied key.

4.3.6 Accessory Holder

The optional accessories like spindle motor, tool holder, tools, vacuum system, etc. are mounted on the accessory holder.

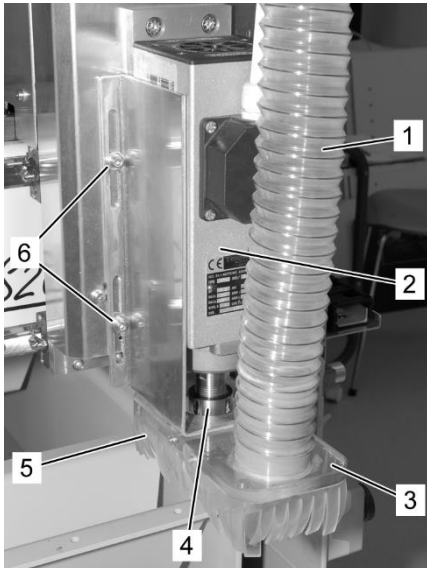

- 1 Extractor/Vacuum System (optional)
- 2 Milling motor (optional)
- 3 Vacuum attachment holder
- 4 Tool holder /milling spindle (optional)
- 5 Protective cover
- 6 Z-Height adjustment screws for manual tool change

Fig. 18: Accessories Holder

4.4 User Controls

The machine does not have any controlling systems and all commands are given by the controlling software installed on a PC.



Further information is available in the software user manual supplied with the software disc.

4.5 Connections

Connections on the controller

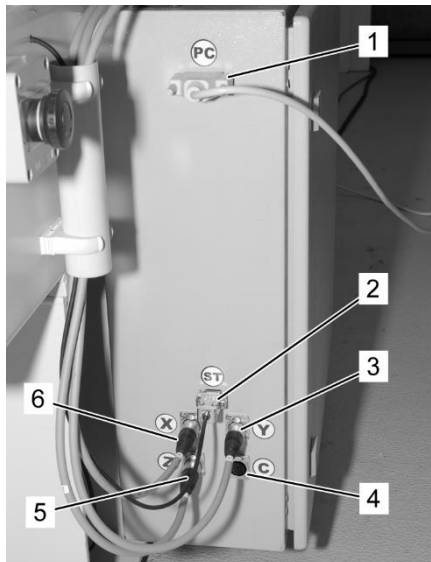

- 1 Connection □ computer with software
- 2 Connection □ emergency-stop switch and r reference switches
- 3 Connection □ Y-motor
- 4 Connection □ C-, A-axis or other optional accessories
- 5 Connection □ Z-motor
- 6 Connection □ X-motor

Fig. 19: controller (rear view)

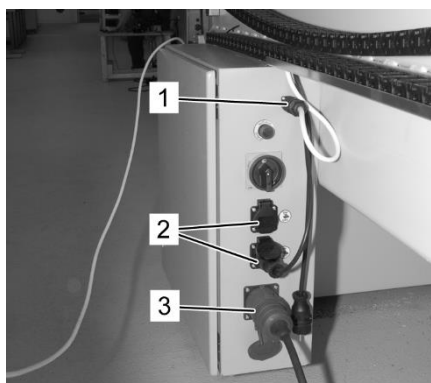

- 1 Connection □ HF-spindle (optional)
- 2 Relay-controlled plug points connected to plug points available on Z-axis (Fig. 21)
- 3 Power supply 380 V

Fig. 20: controller (front view)

Plugs

The plug points are located on the Z-axis. The plugs are 220V supply relay controlled by the software (Fig. 21/1 and 2).

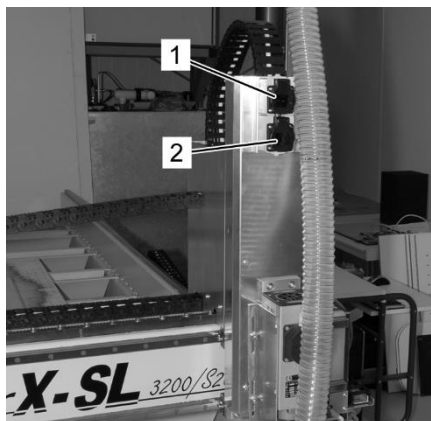

- 1 Plug cooling/vacuum
- 2 Plug milling spindle

Fig. 21: plugs

4.6 Working and Danger Areas

Working areas

- PC (not supplied)
- Inside the clamping area while the machine is switched off
- Inside the cutting area while the machine is switched off

Danger areas

- Complete machine while it is in operation

5 Transportation, Packaging and Storage



Users and service staff of the operator should be informed about the handling of packaging when installing equipment and during further usage. It is absolutely necessary to pay attention to the following information:

5.1 Safety Instructions for Transportation

Hanging or suspended loads



WARNING!

Danger to persons through hanging or suspended loads!

When lifting loads, life threatening danger exists by falling or uncontrolled swinging of objects.

Therefore:

- Never step under hanging or suspended container or loads
- Only move loads under supervision
- Use only approved hoisting devices and sling gear with sufficient carrying capacity.
- Do not use torn or damaged ropes or straps
- Do not fasten ropes and straps at sharp edges and corners, do not knot or twist them.
- When leaving the work place ensure that the load has been put down.

Off balance centre of gravity



WARNING!

Falling hazard by load off balance or centre of gravity

Containers can be harnessed off the centre of gravity. Incorrect harnessing can tip the container and cause life-threatening injuries.

Therefore:

- Pay attention to the markings on the container
- Attach the hoists hook that it is above the centre of gravity
- Lift carefully and observe if the load starts tipping over. If necessary, modify or move the sling or harness.



Inappropriate Transportation



CAUTION!

Damage caused by inappropriate transportation!

Inappropriate transportation can cause significant material damage to property.

Therefore:

- Take care while unloading the container on delivery and internal transport and obey the symbols or icons and markings on the packaging.
- Use only intended attachment points.
- Remove packaging only shortly before assembling.

5.2 Transport Inspection

Check the delivery immediately after receipt for completeness and transport damage.

In case of visible damage proceed as follows:

- Do not accept the delivery or accept only under reservation.
- Record the extent of the damage on the delivery note of the transporter or forwarding agent.
- Initiate a customer complaint.



Complain about any deficiency once it is detected. Damage claims can be asserted only within the applicable time limits.

5.3 Packaging

About Packaging

The individual containers are packed according to the expected transportation conditions. Only environmentally friendly materials are used for the packaging.

The packaging is intended to protect the individual components from transport damage, corrosion and other damage. Therefore, do not destroy the packaging and remove only shortly before assembly.

Dealing with packaging material

Dispose of packaging material in accordance with the currently valid legal regulations and local provisions.



CAUTION!

Environmental damage caused by inappropriate disposal!

Packaging materials are valuable raw materials. In many cases these may be used further or can be sensibly re-used and recycled. Therefore:

- Dispose of the packaging material in an environmentally friendly manner.
- Observe the locally applicable disposal regulations. If necessary, contract a recycling company.

5.4 Icons on the Packaging

The following icons are found on the packaging. These icons descriptions must be observed during transportation.

Fragile



Indicates items with fragile or delicate contents.

Handle container with caution, do not drop or expose to collisions.

Do not stack



Do not stack anything on top of the marked packages or containers.



Keep dry



Protect packages or containers against moisture and keep them dry.

5.5 Transportation

Attachment points

The machine may only be transported and attached on the frame.

Transportation of pallets with the crane

Containers which are mounted on pallets can be transported with a crane under the following conditions:

- Cranes and hoisting devices must be designed for the weight of the containers.
- The operator must be authorized to operate the crane or hoist.

Attaching

Safety equipment: Safety helmet

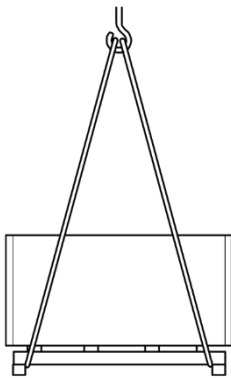

Fig. 22: Attach lifting straps

1. Attach ropes, belts or multi-position hanger according to fig. 22 and secure pallet against sliding.
2. Check, whether the containers are going to be damaged by harnessing or lifting gear. If necessary use other harnesses or belts.
3. Ensure that the pallet cannot tip by incorrect centre of gravity.
4. Start transportation.

Transportation of pallets with a forklift

Containers which are mounted on pallets can be transported with a forklift under the following conditions:

- The forklift must be designed for the weight of the container.
- The container must be firmly secured to the pallet.
- The operator of the forklift must be authorized to use the equipment according to the local industrial regulations.

Transportation

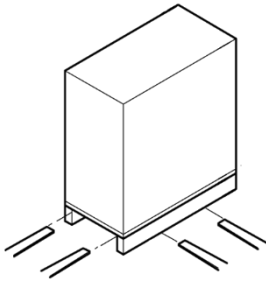

Fig. 23: Transportation with fork lift

1. Drive the forklift with the forks under the beams of the pallet.
2. Insert the forks so far that they protrude the opposite side.
3. Ensure that the pallet cannot tip by incorrect centre of gravity.
4. Lift the pallet with the container and start transportation.

5.6 Storage

Storage of the containers

Store containers under the following conditions:

- Do not store outdoors.
- Store dry and dust-free.
- Do not expose to aggressive media.
- Protect from solar radiation.
- Avoid mechanical agitation.
- Storage temperature: 15 to 35 °C.
- Relative Humidity: max. 60 %.
- During storage longer than 3 month, the general condition of all parts and the packaging needs to be controlled regularly. If necessary, refresh or renew the preservation materials.



It is possible that there are instructions for storage on the packages which override the aforementioned requirements. Comply with them accordingly.



6 Installation and Commissioning

6.1 Safety Information for Installation and Commissioning

Hanging or suspended loads



WARNING!

Danger to persons through hanging or suspended loads!

When lifting loads, life threatening danger exists by falling or uncontrolled swinging of objects.

Therefore:

- Never step under hanging or suspended container or loads
- Only move loads under supervision
- Use only approved hoisting devices and sling gear with sufficient carrying capacity.
- Do not use torn or damaged ropes or straps
- Do not fasten ropes and straps at sharp edges and corners, do not knot or twist them.
- When leaving the work place ensure that the load has been put down.



Incorrect installation and commissioning



WARNING!

Risk of injury caused by incorrect installation and commissioning!

Incorrect installation and commissioning can cause serious personal injuries or property damage.

Therefore:

- Prior to starting installation, ensure that there is sufficient space for the assembly work.
- Handle sharp-edged parts with care.
- Pay attention to orderliness and cleanliness at the assembly place! Loosely stacked or spread parts and tools may cause accidents.
- Mount components correctly. Comply with required bolt torques
- Secure components to ensure that they do not fall
- Before commissioning the following steps must be adhered to:
 - Ensure, that all installation steps have been followed according to the instruction manual
 - Ensure that no persons are inside the working area of the machine

Torque wrench for screws



CAUTION!

Damage caused by incorrect tightening of bolts!

All screws on the CNC milling station have been tightened to the correct torque. Additional tightening of bolts can lead to unwanted tension within the CNC milling station and can cause inaccurate machining of work pieces.

Therefore:

- Do not retighten screws on the machine



6.2 Preparation

6.2.1 Placing Machine

- Staff: Qualified staff
- Safety equipment: Protective clothing
 Safety shoes
 Safety helmet

Inadequate load-bearing structures



WARNING!

Danger to persons due to inadequate load-bearing structures!

Overloading of floors could lead to serious injury or death as well as damage to property!

- If the machine is installed on a suspended floor the dynamic load capabilities must be observed.

Uneven surface



CAUTION!

Damage resulting from installation on uneven surfaced!

An installation on an uneven surface may cause deformation within the CNC machine. This leads to inaccurate machining of work pieces and can cause damage to the machine.

- Install the CNC machine on a plane and level surface.

Setting-up machine

1. The machine must be installed with the prescribed method of attachment on a level, vibration-resistant and fully hardened foundation or floor.



In doubt have all of the required loads checked by a qualified building engineer.

2. Remove all transportation equipment and packaging on the machine at the place of installation.

Levelling of the machine



A precision spirit-level capable of 0.02mm accuracy (Fig. 24) is included in the scope of delivery. Use the supplied spirit level to level out the CNC machine correctly. Adjustments can be made on the feet found on each corner of the machine.

Fig. 24: machine spirit level

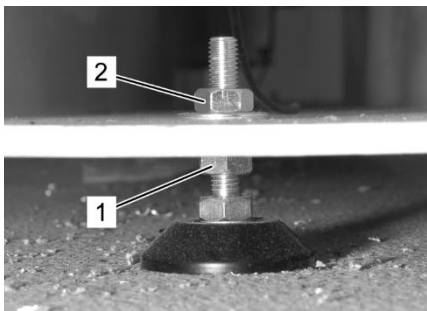

Fig. 25: adjustable foot

1. Loosen the lock nut (Fig. 25/2) with a 17mm spanner.
2. Adjust height by using 17mm spanner on adjusting nut (Fig. 25/1).
 - turn clockwise to lower table,
 - turn anti-clockwise to raise the table.
3. Use the spirit level to check the accuracy and if required repeat step 2.
4. When done, secure the lock nut (Fig. 25/2) with a 17mm spanner.
5. Check that all axis are free to move.

6.2.2 Adjusting Table Top

The table top (optional) must be sized according to the clamping area of the machine.

Raptor X-SL Series	Maximum length of table top in mm	Maximum width of table top in mm
S-1200/S15	1500	1700
S-1200/S20	1500	2200
S-2200/S15	2500	1700
S-2200/S20	2500	2200
S-3200/S15	3500	1700
S-3200/S20	3500	2200

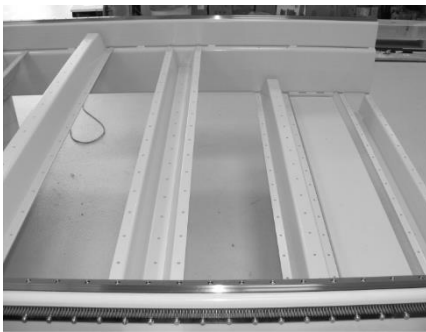

Fig. 26: table top support struts may be installed on 4 different heights

The open frame allows for the adjustment of the height of the worktop support to be increased from 50mm to 850mm.

The work table will be placed on top of the table top support struts (Fig. 26) at whichever particular height is chosen.

This will allow the bridge height to clear either 50/150/300/400mm.

When the table support struts are removed completely large work pieces may be mounted on the floor up to a maximum height of 850mm however with restriction in X-axis movement.

Staff: Qualified staff

Safety equipment: Protective clothing

Safety shoes

Safety helmet

Table top height adjustment

1. Remove the table top from the support struts.
2. Loosen Allan screws on each support strut using the correct Allan key.
3. Move support struts to the correct height and refasten.



The supports struts may be inverted.

4. Replace the table top on the support struts and refasten.
5. Use the spirit-level to check that the table top is level in the x- and Y-directions.

6.3 Installation

6.3.1 Connecting the Computer

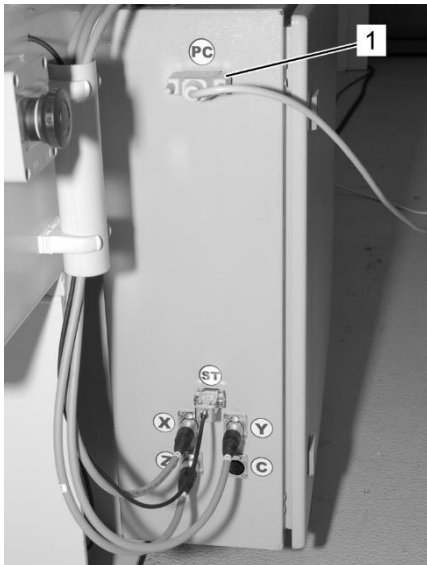

The computer will be connected to the machine via a DSUB-25-pin parallel connection (Fig. 27/1). The other side will be connected to the computer via a parallel port connection.

Depending on the type of software used (e. g. WinPCNC USB or WinPCNC Profi) the connection to the computer may be via USB port or serial port.

Staff Operator

1. Attach cable from computer to the controller (Fig. 27/1).
2. Ensure that all cables have been screwed into their connectors securely.

Fig. 27: Connection to Computer

6.3.2 Connecting the Stepper Motors



CAUTION!

Risk of stumbling and resulting injury through cables lying around!

Cables lying around on the floor are a source for slipping and stumbling and can result in serious injuries.

- Always cover any exposed cables lying on the floor.
- Do not route cables across sharp edges or corners.
- Avoid rubbing of cables on machine.
- Always insure that cable channels are visible.

The stepper motor plugs and the controller are labelled.

Staff Qualified staff



Fig. 28: controller

1. Connect the connector plugs in the correctly labelled plug point on the controller (Fig. 28):
 - Stepper motor X-axis in connection X
 - Stepper motor Y-axis in connection Y
 - Stepper motor Z-axis in connection Z
 - Stepper motor C- or A-axis in connection C (optional)
 - Stepper motor oscillating knives in connection Cutter (optional)
 - Emergency Stop- and Reference-Switches in connection ST
2. Fasten connectors with a screw driver if required.



6.3.3 Installing Accessories



The installation of the accessories must be done according to the relevant accessory instruction manual.

Power may be supplied by the two relay controlled plug points

□ Chapter 4.5 "Connections", page 51.



WARNING!

Risk of injury due to incorrectly mounted accessories!

Incorrectly mounted accessories may fall off or cause object to be ejected during operation causing injuries to persons.

- Always mount the accessories safely and correctly.

6.4 Connecting to Power Supply

Connecting the machine to the power supply



CAUTION!

Risk of stumbling and resulting injury through cables lying around!

Cables lying around on the floor are a source for slipping and stumbling and can result in serious injuries.

- Always cover any exposed cables lying on the floor.
- Do not route cables across sharp edges or corners.
- Avoid rubbing of cables on machine.
- Always insure that cable channels are visible

Staff: Electrician

1. Compare the power supply available with the requirements of the machine and connect only if the values match.
2. Before connecting power to the machine ensure that the supply has been switched off from the main distribution.
3. Use the correct 5-pole 3-phase plug from the main power supply and on the machine.
4. Once cables have been connected the main power supply may be switched on.

6.5 Commissioning

Staff: Qualified Staff

1. Ensure that the machine has been levelled as required in
 Chapter 6.2.1 “Placing Machine”, page 60
2. Ensure that all of the connections from the motors have been correctly plugged in, see *Chapter 6.3.2 “Connecting the Stepper Motors”, page 64.*
3. Ensure that the computer has been connected to the controller; see *Chapter 6.3.1 “Connecting the Computer”, page 63.*
4. Ensure that the accessories have been installed and plugged in correctly.
5. Ensure that the software has been installed on the PC and is working correctly.
6. Ensure that all plugs are seated properly.

The initial movements of the axis may be performed using the “JOG”-function in the controlling software to test the movements of the machine.



The Components of the machine will have different expansion coefficients. At an ambient temperature of 20-25 °C the machine will perform correctly. Operating outside of the required ambient temperature may result in loss off accuracy.

7 Operation

7.1 Safety Instruction for Operation

Incorrect operation



WARNING!

Risk of injury by incorrect operation!

Incorrect operation can cause severe injury to persons and damage to property.

- Carry out all operating steps according to the details in this instruction manual.
- Before using the machine check the following points:
 - Ensure that all covers and safety devices are installed and work properly.
 - Ensure that no persons are inside the working area of the machine.
- Never disable or bridge safety devices.

7.2 Important Steps before Operation

1. Ensure that all covers have been installed and fastened properly.
2. Check that all plugs and sockets are securely mounted.
3. Ensure that all emergency stop switches have been released.
4. Ensure that the controller door is securely shut.
5. Check ambient temperature.



The Components of the machine will have different expansion coefficients. At an ambient temperature of 20-25 °C the machine will perform correctly. Operating outside of the required ambient temperature may result in loss off accuracy.

7.3 Switching-On Procedure

Staff: Operator

1. Switch on the computer and launch the software.
2. Clamp work pieces *Chapter 7.4.1 "Clamping of Work Pieces or Materials", page 69.*
3. Ensure that the correct tools have been installed in the tool holder, *Chapter 7.4.3 "Tool Changes", page 75.*
4. Ensure that no other work pieces or equipment is in the working areas of the machine.
5. Ensure that there are no persons inside the working area.
6. Ensure that the correct accessories have been switched on.
7. Turn the main switch on the controller to the "I" or "On" position.
 - The machine controller will be energized.
8. Perform a reference run in the software.
9. Start the cutting process.

7.4 Important Steps during Operation

7.4.1 Clamping of Work Pieces or Materials

Examples of clamping flat and complex work pieces

Staff: Operator

Safety equipment: Protective clothing
 Safety shoes
 Safety goggles
 Safety gloves

1. In the event of working with spray cooling a waterproof table top must be installed.
2. Mill the surface of the worktable flat.

3. Install the t-groove plates on the plane surface of the table top or directly mount the work piece on the table top with clamps or screws.

Mounting flat materials or materials to be engraved

Staff: Operator

Safety equipment: Protective clothing

Safety shoes

Safety gloves

1. In the event of working with spray cooling a waterproof table top must be installed.
2. Mount a flat sacrificial piece of material on the surface of the table top.
3. When engraving an engraving depth regulator (optional) may be used to ensure a constant engraving depth over uneven materials.

7.4.2 Operating of the Machine

Staff: Operator

Safety equipment: Protective clothing

Safety shoes

Safety goggles

Safety gloves

Ear protection

Hairnet



Rotating tools



WARNING!

Risk of injury by rotating parts!

The milling tools clamped in the spindle motor can cause serious injury to persons or damage to property

- Before start of work verify that the safety devices are functional and installed properly and that the required covers are closed.
- During operation do not touch the rotating tools
- Before changing tools always secure machine against an accidental restart or uncontrolled movements.

Moving Axis



WARNING!

Risk of injury by moving axis!

Collisions between persons and machine (Y-Axis, Moving parts, Rotational axis, Tools) may lead to serious injuries.

- Keep clear of moving parts and their end-stops
- Never reach between the machine and rails
- Only perform maintenance on linear guides when machine is switched off
- Always wear protective clothing in the work area.



Rack and Pinion



WARNING!

Risk of injury by moving rack and pinion gear
While operating clothing, hair or body parts could get caught in the rack and pinion leading to serious injury.

- Never reach over rack and pinion when machine is switched on.
- Maintenance may only be performed while the machine is turned off.
- Always wear protective clothing in the working area.

Magnetic field radiation



DANGER!

Danger from magnetic field radiation!

Magnetic fields pose a danger to persons and property

- Persons with Pace-Maker may should not work on or approach the machine. The Pace-Maker may be affected.
- Persons with metal implants should not work on or approach the machine. The implants may heat up or be pulled towards the machine.
- Do not wear any jewellery like rings, necklaces, watches etc. when operating the machine.
- Do not place any electronic equipment near the magnetic fields as these may be damaged
- Do not place any data storage devices or credit cards, etc. near the magnetic fields as these may be wiped out.



Falling materials



WARNING!

Risk of injury by falling materials!

While operating off cut debris, materials or tools may be ejected from the work area causing serious injury to face or eyes

- Always wear face and eye protection, gloves and safety shoes
- In the event of an injury, contact the medical personnel

Uncontrolled restart



WARNING!

Uncontrolled restart can cause serious personal injury or death!

The machine could move unexpectedly or change direction unexpectedly resulting in injury

- Keep body parts away from the machine working area
- Secure work area against accidental access.



Highly flammable materials



WARNING!

Danger of fire through flammable materials!

Organic dust from wood or coal and inorganic dust from Magnesium, Aluminium, Zink or Titanium may start combusting which may result in serious injury or death

- Do not smoke near the working or danger area and avoid open flames or other potential fire risks.
- Always have a fire extinguisher near the machine.
- When working with Magnesium, Aluminium, Zink or Titanium an extraction system is required and caution must be observed.
- In case of fire, stop working and evacuate the area. Activate the fire alarm.

Cooling fluids



CAUTION!

Health risk from exposure to toxic cooling fluids!

Contact with Toxic coolants can result in illness

- Avoid direct skin contact.
- Wash skin immediately after contact with coolants.
- Avoid breathing fumes or gases from the coolants.

No special CNC programming skills are required to run the machine. The work process is done by the CNC operating software and motor stepper controllers.

To reduce the wear and tear of components to not exceed 80% of the maximum traverse speed, see *Chapter 3.3 “Power Usage”, page 40.*



For further information see user manual for the software installed.



Operation of the accessories will be explained in the user manual for the respective accessory used.

7.4.3 Tool Changes

Staff: Operator

Safety equipment: Protective clothing

Safety shoes

Safety gloves

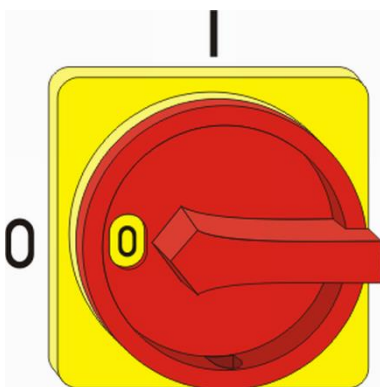

Fig. 29: Main Switch

1. Turn the main switch to the "0" or "Off" position (Fig. 29).

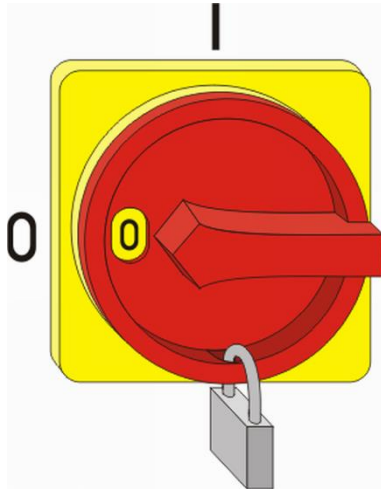

Fig. 30: Lock the main switch

2. Lock the switch in the off position to prevent restart (Fig. 30).

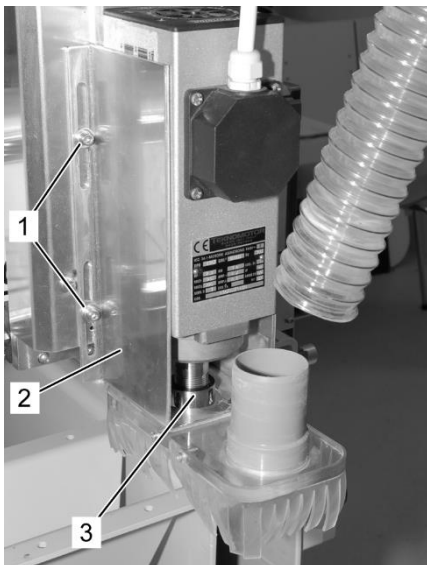

Fig. 31: Tool holder

3. Loosen the screw retaining the vacuum protection cover (Fig. 31/2) on both sides (Fig. 31/1) and push the vacuum protection cover upwards to expose the spindle collet from below (Fig. 31/3)
4. Refasten the screws on both sides of the cover (Fig. 31/1).



CAUTION!

Danger of injury from hot surfaces and sharp edges!

Tools, work-pieces and chippings may heat up to high temperatures. Contact with these surfaces could result in severe burns or cuts to the skin from sharp chippings.

- When changing tools always wear gloves.

5. Tool changes, □ refer to separate user manual for milling spindle or other tools.

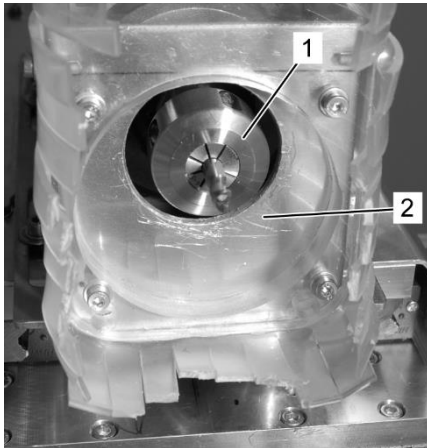

Fig. 32: Spindle collet

6. After tool change loosen the screws (Fig. 31/1) on the vacuum protection (Fig. 31/2) on both sides and lower back down to the correct position in line with collet (Fig. 32/1) with new tool installed (Fig. 32/2).
7. Switch on main switch to the “I” or “On” position.

7.5 Switching-Off Machine

1. Switch the main switch on the controller into the "0" or "Off" position.
 - The controller will be switched off.
2. Shut down the software on the computer.
3. Switch off the computer.

7.6 Important Steps after Operation

Staff: Operator

Safety equipment: Protective clothing

Safety shoes

Safety gloves

1. Turning off the machine *Chapter 7.5 "Switching-Off Machine", page 77.*



CAUTION!

Danger of injury from debris!

Chips or shavings can be sharp edged and can cause deep cut wounds.

- Always wear protective gloves when removing debris from the machine.

2. Clean the machine □ *Chapter 8.4.1 “Cleaning Machine”, page 83.*

7.7 Emergency Stop

In an emergency situation the movements of the machine must be stopped as quickly as possible and the power supply must be switched off.

Emergency stop

In the event of a dangerous situation act as follows:

1. Press emergency stop immediately.
2. If there is no danger for your own health, rescue persons out of the danger area.
3. If necessary start first-aid measures.
4. Alert fire and rescue service.
5. Inform person in charge of location.
6. Switch off machine and secure against restart.
7. Clear access roads for emergency vehicles.
8. Instruct emergency vehicles.

8 Maintenance

8.1 Safety during Maintenance

Moving parts



WARNING!

Risk of injury by moving parts!

Rotating and/or linear moving parts may lead to serious injuries.

- Prior to maintenance work switch off machine and secure against restart. Wait till all parts came to a complete standstill.
- Wear tight-fitting protective clothing with low tensile strength in the danger area.

Electrical system



DANGER!

Life threatening danger by electrocution!

Contact with live or electrified parts can present a life threatening danger. Activated electrical components can cause uncontrolled movements and can cause serious injuries.

- Before starting work switch off the power supply and secure against restart.

Incorrectly done maintenance work



WARNING!

Risk of injury by incorrectly done maintenance work!

Incorrectly done maintenance work can cause severe damage to person or property.

- Prior to start working ensure that there is sufficient space for the assembly work.
- Pay attention to orderliness and cleanliness at the assembly place! Loosely stapled or spread out parts and tools may cause accidents.
- If parts have been removed, ensure correct re-assembly, re-install all fastening elements and observe torque specification for screws and bolts.
- Before restarting observe the following:
 - Ensure that all maintenance work has been done according to user manual and has been completed.
 - Ensure that there are no persons in the working area of the machine.
 - Ensure that all covers and safety switches are installed and working properly.

Environmental protection

Observe the following details for environmental protection during maintenance work:

- Remove any excess grease and dispose of it in accordance with the applicable local regulations.
- Collect exchanged oils in an appropriate container and dispose of it in accordance with the applicable local regulations.

8.2 Spare Parts



WARNING!

Risk of injury due to the use of incorrect spare parts!



The use of incorrect spare parts can result in injury to persons or damage to property or incorrect functioning of the machine.

- Only use original spare parts from the manufacturer or parts authorized by the manufacturer.
- If any uncertainty exists please contact the manufacturer.



Loss of Guarantee

The use of incorrect spare parts may result in the loss of guarantee on the machine.

Spare parts may be ordered from the manufacturer or the agents.
For contact details see page 2.

A complete parts list is available on request.

When ordering spare parts please quote the following:

- Model
- Serial-No.
- Amount
- Description
- Preferred delivery method (Sea- or Air freight, post, courier, etc.)
- Delivery address

Any spare parts ordered without the above mentioned details will not be processed. If the method of shipment has not been stated this will be decided by the supplier.

8.3 Maintenance Schedule

In the following section the maintenance work to be done is described to ensure the optimum and break-down free operation of the machine.

In the event that by regular inspection and increased wear and tear is noticed please shorten the maintenance intervals. If uncertain please contact the manufacturer, see contact details on page 2.

Interval	Maintenance Work	To be done by
Daily	Clean machine □ <i>Chapter 8.4.1 “Cleaning Machine”, page 83</i>	Operator
	Check protective plastic covers for damage, change if damaged □ <i>Chapter 8.4.2 “Protection Cover Inspection or Replacement”, page 83</i>	Operator
	Check machine for damage or wear	Qualified staff
10 operating hours	Lubricate linear guides and rack □ <i>Chapter 8.4.3 “Machine Lubrication”, page 86</i>	Qualified staff
50 operating hours	Grease the machine through the grease nipples □ <i>Chapter 8.4.3 “Machine Lubrication“, page 86</i>	Qualified staff
When necessary	Clean the outside of the machine with a soft, dust free cloth	Operator



The maintenance of the accessories is referred to in the respective user manual.

8.4 Maintenance Procedures

8.4.1 Cleaning Machine



Performing regular maintenance on the machine will prevent any moving parts from sticking.

- Staff: Operator
- Safety equipment: Protective clothing
 Safety shoes
 Safety gloves

1. Turn off the machine *Chapter 7.5 “Switching-Off Machine“, page 77.*

2.



CAUTION!
Danger of injury from debris!

Chips or shavings can be sharp edged and can cause deep cut wounds.

- Always wear protective gloves when removing debris from the machine.

Clear the machine of any debris.

3. Clean and grease the rack and linear guides separate user manual.

8.4.2 Protection Cover Inspection or Replacement

Check protective cover for damage

- Staff: Operator
- Safety equipment: Protective clothing
 Safety shoes

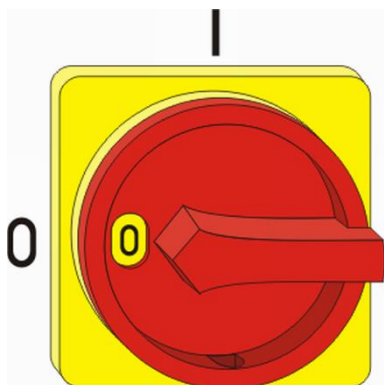

Fig. 33: main switch

1. Turn the main switch to the "0" or "Off" position (Fig. 33).

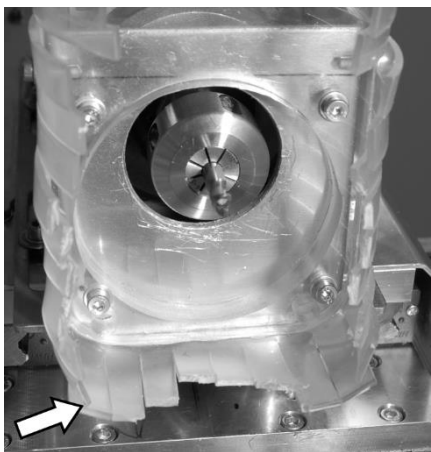

Fig. 34: protective cover

2. Check the protective cover (optional vacuum system) (Fig. 34/arrow) for damage.



If the protective cover is damaged, replace it, see
□ Chapter 8.4.2 "Protection Cover Inspection
or Replacement", page 83.

Replace protective cover

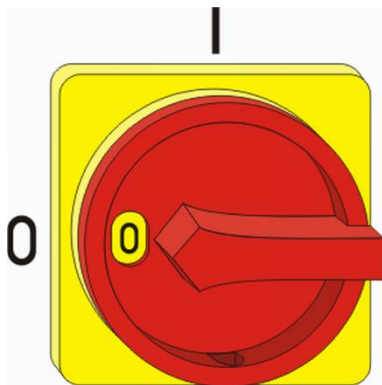

Fig. 35: main switch

1. Ensure that the main switch is in the "0" or "Off" position (Fig. 35).

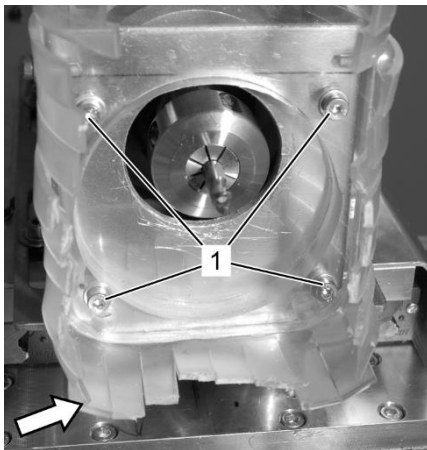

Fig. 36: protective cover

- 2.



CAUTION!

Danger of injury from hot surfaces and sharp edges or tools!

Tools, work-pieces and chippings may heat up to high temperatures. Contact with these surfaces could result in severe burns or cuts to the skin from sharp chippings.

- Ensure that the tools or tool holder have cooled to ambient temperature.
- When changing tools always wear gloves.

Remove four screws (Fig. 36/1).

3. Remove protective plastic cover (Fig. 36/arrow).
4. Install new cover with four screws (Fig. 36/1).

8.4.3 Machine Lubrication



Information on lubricants □ *Chapter 3.5*
“Lubricants“, page 41.

Lubrication of linear guides and racks

- Staff: Qualified staff
- Safety equipment: Protective clothing
 Safety shoes
 Chemical resistant gloves

1. Switch off machine and secure against restarting.



Caution!

Health risk from exposure to oils and grease!

Contact with Toxic coolants can result in illness.

- Avoid direct skin contact.
- Remove oil or grease from skin immediately
- Avoid breathing fumes or gasses from oils or grease.

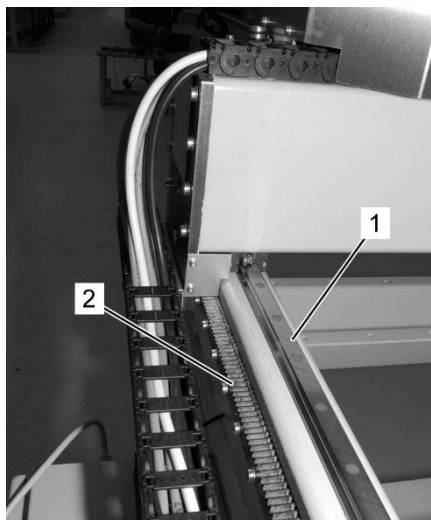

Fig. 37: X-axis

2. Grease both sides of the X-axis linear guides (Fig. 37/1) and racks (Fig. 37/2) with a light machine grease using a lint free cloth.



Fig. 38: Y-axis

3. Grease the linear guides (Fig. 38/1) of the Y-axis with light machine grease using a lint free cloth.



Fig. 39: Y-axis

4. Grease the rack (Fig. 39/2) of the Y-axis with a light machine grease using a lint free cloth.

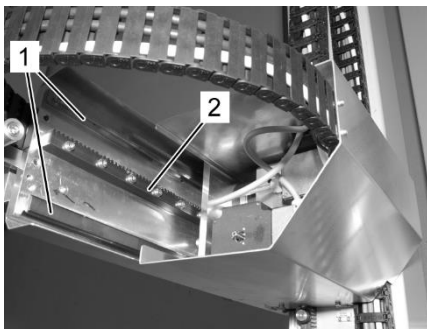

Fig. 40: Z-axis

5. Grease the linear guides (Fig. 40/1) and the rack (Fig. 40/2) of the Z-axis with a light machine oil using a lint free cloth.

Applying grease through the grease nipples

- Staff: Qualified staff
- Safety equipment: Protective clothing
 Safety shoes
 Chemical resistant gloves
- Special tools: Grease gun

Grease nipple on the X-axis (4x) 1. Switch off machine and secure against restarting.



Caution!

Health risk from exposure to oils and grease!

Contact with Toxic coolants can result in illness.

- Avoid direct skin contact.
- Remove oil or grease from skin immediately
- Avoid breathing fumes or gasses from oils or grease.

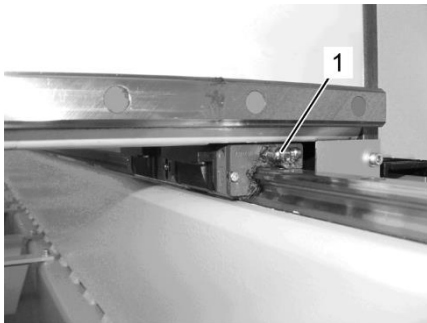

2. Remove protective cap from the grease nipple of the X-axis (Fig. 41/1), if present.



If there are no protective caps on the grease nipples, clean the nipples before using.

Fig. 41: Grease nipple X-axis

3. Attach grease gun to the grease nipple.
4. Press grease gun once or twice.
5. Remove grease gun.
6. Replace grease nipple cap.
7. Repeat steps 2-6 for all grease nipples.

Grease nipple on the Y-axis (4x)

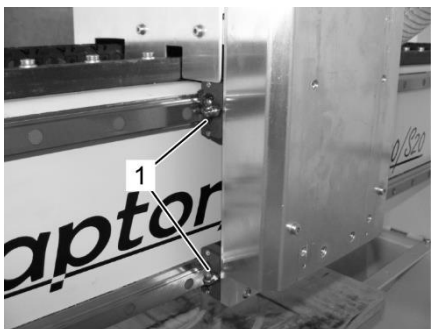

Fig. 42: Grease nipple on Y-axis

1. Switch off machine and secure against restarting.
2. Remove protective cap from the grease nipple of the Y-axis (Fig. 42/1), if present.



If there are no protective caps on the grease nipples, clean the nipples before using.

3. Attach grease gun to the grease nipple.
4. Press grease gun once or twice.
5. Remove grease gun.
6. Replace grease nipple cap.
7. Repeat steps 2-6 for all grease nipples.

Grease nipple on the Z-axis (4x)

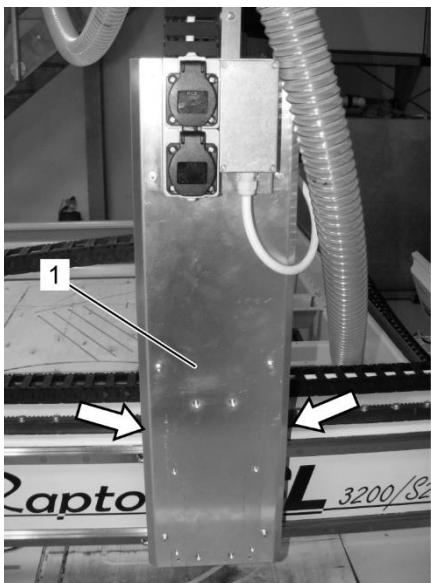

Fig. 43: Grease nipples Z-axis (arrows)

The grease nipples on the Z-axis are found behind the cover plate on the Z-axis (Fig. 43/1).

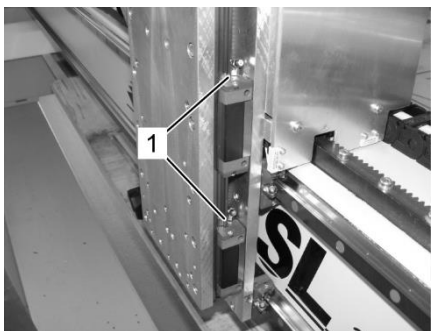

Fig. 44: position of the grease nipples without the cover on the Z-axis

There are four grease nipples (Fig. 44/1), two on each side of the Z-axis.

In the cover plate of the Z-axis (Fig. 44/1) there is a hole on each side. The Z-axis must be positioned so that the grease nipples are visible through the two holes.

1. Switch off machine and secure against restarting.
2. Position Z-axis so that the grease nipples are aligned with the holes in the cover (Fig. 43/arrow).
3. Remove protective caps from the grease nipple of the Z-axis (Fig. 44/1), if present.



If there are no protective caps on the grease nipples, clean the nipples before using.

4. Attach grease gun to the grease nipple.
5. Press the grease gun once or twice.
6. Remove the grease gun.
7. Replace the grease nipple cap.
8. Perform the same on the other side of the Z-axis.
9. Repeat steps 5-7.
10. Position the Z-axis so that the second set of grease nipples are aligned with the holes in the cover (Fig. 43/arrows).
11. Repeat steps 4-7 with the second set of nipples.

8.5 Steps to be taken after Maintenance Procedure

After completion of maintenance work and before restarting the machine, carry out the following steps:

1. Check that all screws and bolts have been replaced and tightened.
2. Check if all removed safety devices and covers have been replaced and are functional.
3. Ensure that all used tools, materials and other equipment has been removed from the work area.
4. Clean work area and remove any spilled liquids, working materials, tools etc.
5. Ensure that all safety devices are working properly.

9 Trouble Shooting

The following chapter describes possible causes for faults and the actions to be taken to rectify the fault.

If the fault occurrence increases, shorten the maintenance intervals according to the actual load.

In the event of faults which cannot be cleared by the following instructions contact the manufacturer, contact details see page 2.

9.1 Safety during Trouble Shooting

Electrical system



DANGER!
Risk of death by electrocution!

Contact with live electrical parts presents an imminent danger to persons and may also caused uncontrolled movements of the machine which may lead to serious injury.

- Before beginning work turn off the main electricity supply to the machine and secure against being turned on accidentally.

Moving parts



WARNING!
Risk of injury by moving parts!

Rotating and/or linear moving parts may lead to serious injuries.

- Prior to maintenance work switch off machine and secure against restart. Wait till all parts came to a complete standstill.
- Wear tight-fitting protective clothing with low tensile strength in the danger area.



Incorrect repairs



WARNING!

Risk of injury caused by incorrect repairs!

Incorrect repairs can cause serious personal injuries or property damage.

Therefore:

- Prior to starting repairs, ensure that there is sufficient space for the assembly work.
- Pay attention to orderliness and cleanliness at the assembly place! Loosely stacked or spread parts and tools may cause accidents.
- Mount components correctly. Comply with required bolt torques.
- Secure components to ensure that they do not fall.
- Before restarting the machine the following steps must be adhered to:
 - Ensure, that all installation steps have been followed according to the instruction manual
 - Ensure that no persons are inside the working area of the machine
 - Ensure that all covers and safety devices have been properly installed and are functional

Steps to be taken in case of fault occurrence As a general rule::

1. In case of faults which present an imminent danger to persons or property, activate the emergency-stop switch immediately.
2. Determine the cause of malfunction.
3. If the fault repair requires work in the danger area, switch off and secure against restart.
Inform the person in charge about the fault.
4. Depending on the nature or the type of fault, either qualified staff or the operator may clear the fault.



The following table of faults shows who may clear the fault.

9.2 Table of Faults

Fault	Possible cause	Troubleshooting	Repair by
Smoking control unit	Control unit defective	Switch off main power supply immediately and contact the manufacturer.	Manufacturer
Machine is not starting	Emergency stop activated	Release emergency stop switch □ <i>Chapter 9.3.1 “Releasing the Emergency Stop Switch“, page 97</i>	Operator
	Blown fuse	Change fuse □ <i>Chapter 9.3.2 “Changing the Electrical Fuse“, page 97</i>	Electrician
Crackling or scraping noise when driving the axis	PCI-Interface defective	Stop working and contact manufacturer.	Manufacturer

Hardlock fault	USB-Dongle not found (WinPCNC Economy)	Ensure that the USB-Dongle is installed correctly.	Operator
Real-Time module blocked	Other programs running in the Windows background.	Close any other programs which are running in Windows.	Operator
Machine runs for a short time and stops abruptly.	USB-Dongle is not installed correctly or is absent (WinPCNC Economy)	Ensure that the USB-Dongle is installed correctly	Operator



If the fault is not listed in the fault table contact customer support, see Chapter Fehler! Verweisquelle konnte nicht gefunden werden. "Fehler! Verweisquelle konnte nicht gefunden werden.", page Fehler! Textmarke nicht definiert.. For trouble shooting of accessories refer to the respective user manual.

9.3 Fault Repair

9.3.1 Releasing the Emergency Stop Switch

Staff: Operator

1. Establish the cause of the fault and repair.
2. Release the emergency stop switch by twisting (Fig. 45).

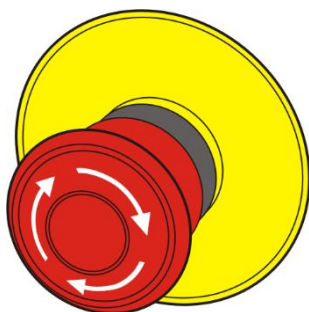
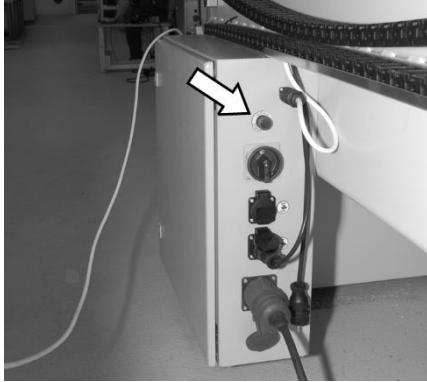

Fig. 45: Emergency stop switch



If the emergency stop switch on the controller (Fig. 46/arrow) is pressed; it will need a double unlocking action.

Fig. 46: controller

9.3.2 Changing the Electrical Fuse

Staff: Electrician

Special tool: Square key



DANGER!

Risk of death by electrocution!

The controller is not protected by any safety devices. If the main power supply is on there is danger of touching electrified components causing injury or death.

- Always switch off the main power supply and secure against accidental switching on before working on the controller unit.

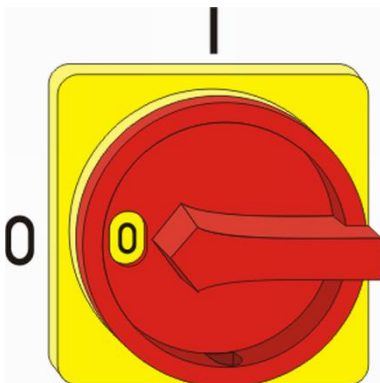

Fig. 47: Main switch

1. Turn the main switch to the "0" position (Fig. 47).

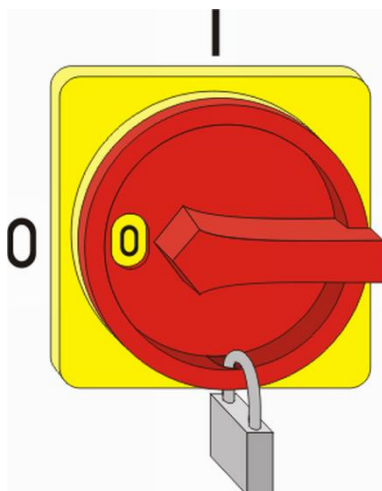

Fig. 48: Secure main switch

2. Secure against restarting by using a padlock (Fig. 48).



DANGER!

Risk of death by electrocution from stored energy!

Electrical charge may be stored in electrical components which could result in electrocution causing injury or death.

- Before commencing work, turn of the power and wait for 10 min before continuing, to allow condensers time to discharge the stored current.

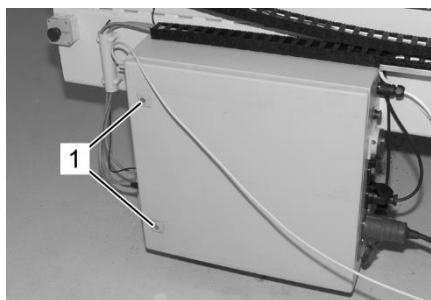

Fig. 49: Controller

3. Open the controller using the square key supplied (Fig. 49/1).
4. Open the door of the controller unit.
5. Change fuse.
6. Close and lock door with square key.
7. Switch on main power supply.

9.4 Start-up after Fault Repair

After repairing a fault, carry out the following steps to restart:

1. Reset the emergency stop switches.
2. Acknowledge the faults in the controlling software.
3. Ensure that there are no persons in the danger area.
4. Restart operating according to chapter 7 “Operation”, page 68.

10 Disassembling and Disposal

When the end of the machines useful life span is reached, the machine must be disassembled and disposed off according to environmental standards.

- Only specially trained or qualified staff may carry out the disassembly.
- Only qualified electricians are allowed to perform work on the electrical system.

10.1 Safety during Disassembling and Disposal

Incorrect disassembling



WARNING!

Risk of injury caused by incorrect disassembling!

Stored residual energies, sharp edged parts, spikes and corners on and in the machine or from the installed tools can cause injuries:

- Prior to starting work ensure that there is sufficient space.
- Handle sharp-edged parts with care.
- Pay attention to orderliness and cleanliness at the work place! Loosely stacked or spread out parts and tools may cause accidents.
- Disassemble components professionally. Be aware of the heavy weight of the parts. If necessary use hoisting devices.
- Secure parts in order that they do not fall or tumble
- If in doubt consult manufacturer.

10.2 Disassembling

Before beginning the disassembling:

- switch off machine and secure against restarting.
- Physically separate entire power supply from the machine, discharge stored residual energy.

- Remove operating and auxiliary materials as well as remaining working materials and dispose of them according to the environmental standards.

Clean assemblies and components professionally and dispose of in accordance with the valid local labour and environmental protection regulations.

10.3 Waste Disposal

Provided that no agreement regarding return or disposal has been made, recycle disassembled parts:

- Scrap the metals.
- Recycle plastic components.
- Dispose of remaining components according to the material characteristics.



CAUTION!

Environmental damage caused by incorrect disposal!

By incorrect disposal, waste may present a danger to the environment.

- Electrical components, lubricants and other materials are special hazardous waste and may only be disposed by licensed specialists.
- The local authority or specialized waste management companies can provide information about environmentally correct disposal.

11 Appendix

11.1 Accessories

For the machine, there is a wide variety of applications.

Here is an excerpt from our catalogue of comprehensive range of accessories:

Machine extensions

- Enclosures, sub-racks, power arms,
- T-slot plates, T-slot plates on head frame

Work holding

- Vacuum tables and pumps, clamps, nuts

Tools milling, engraving, drilling

- Spindles, tool change spindles, collets, etc.
- Cutter for many different applications and materials, engraving, drill
- Axes of rotation and jaw chuck, depth sensor, tool length sensor, suction, minimum quantity lubrication etc.

Tools for various applications

- Tangential cutting (oscillating or fixed)
- grooving module
- Laser engraving unit
- Laser scanning unit
- Plasma torch
- GranitoGrav (module for stone engraving)

Hardware and Software

- PC's and Monitors
- Radio remote control
- CAD / CAM software, font packs, specialized software

If interested, please contact our Customer Service by email or phone.

We will be pleased to advise you and give you an exact offer for your requirements!

Numerous suggestions and information is also available on our website.

12 Customer Service

For technical information, please contact our Technical Customer Service:

Address:	CNC-STEP e.K. Siemensstraße 13-15 D-47608 Geldern	
Phone:	+49 (0)2831/91021-50	(Mo. - Fr. 07.00 - 15.00 Uhr)
Mobile:	+49 (0)2831/91021-20 Only in urgent cases	(Mo. - Do. 15.30 - 18.00 Uhr)
Fax:	+49 (0)2831/91021-99	
E-Mail:	support@cnc-step.de	
Web:	<i>https://www.cnc-step.de/en</i>	

If you have questions, please contact our customer service via e-mail or phone.
We advise you gladly.

Numerous suggestions and information can be found on our website:

<https://www.cnc-step.de/en>